

” CATALOGO “



con&con





con&con



**Relax . comfort . appendere . sostenere . portare
contenere . archiviare . fermare . mostrare . segnalare
nascondere . trasportare . muovere . fare**

Dietro ad ogni verbo si nascondono le piccole grandi azioni di ogni giorno. Si può appendere un grembiule come un bellissimo abito da sera. Si può archiviare un documento come una lettera d'amore.

Ciò che cambia sono lo stile e la forma degli oggetti a cui si appende o con cui si sostiene qualcosa, oggetti che trovano la loro ragione di essere proprio grazie a queste azioni.

Per questo Con&Con ha deciso di raggruppare i suoi prodotti identificandoli con le singole azioni per le quali sono stati progettati, trasformandoli da semplici accessori per la casa in soluzioni di arredamento per le nuove esigenze dell'uomo e dello spazio con cui interagisce.

Questo è il credo di Con&Con.
Un credo di cui parla ogni suo singolo prodotto, raccontando una storia di ricerca e di design in continua evoluzione.

**Relax . comfort . hanging . supporting . bearing
containing . storing . stopping . displaying . indicating
hiding . transporting . moving . do**

Each of these verbs denotes the minor, yet important actions you perform every day. You hang an apron in the same way that you hang a stunning evening gown. Now you can store a document like a love letter. What changes is the style and the shape of the objects that you are hanging or which you use to support something...objects whose ultimate purpose depends on the actions themselves.

For this reason, Con&Con has decided to group its products by identifying them with the individual actions they were designed to perform, thus transforming them from being simple accessories made for the home into advanced furnishing solutions that enable the home to meet the new requirements of Man and the space he interacts with. This is the creed of Con&Con.

It is a creed that the company expresses in each of its products through research and a continuously evolving design philosophy.

"In plastica".

Il rapporto tra l'uomo e gli oggetti che lo circondano è mutato con il mutare dei ritmi e degli stili di vita.

Gli oggetti dal tradizionale concetto di casa migrano per abitare nuovi luoghi articolati e multifunzionali.

Luoghi in cui la plastica assume un ruolo preponderante, rappresentando una sfida ed un punto di partenza per la costruzione di spazi e idee assolutamente innovative.

Questa potrebbe essere in sintesi la nuova filosofia di Con&Con.

Un approccio che tende a nobilitare un materiale fino ad oggi ritenuto il "surrogato economico" di altri materiali, attribuendo così alla plastica un valore cosciente, intrinseco, un materiale capace di forti potenzialità espressive oltre che tecniche e funzionali. Opaca o trasparente, gofrata o liscia, coloratissima o elegantemente naturale, monomaterica o strutturalmente aggregata, la plastica è capace di offrire straordinarie metamorfosi estetiche e linguistiche.

"In plastic".

The relationship between Man and the things that surround him has changed as the pace and style of life have changed.

Objects expressing a traditional concept of the home are now being used in new, multifaceted, multipurpose areas where plastic plays a predominant role. Thus, the use of plastic represents both a challenge and a starting point for the creation of innovative settings and ideas. This principle sums up Con&Con's new, ground-breaking philosophy. Con&Con's approach is to uplift a material that has traditionally been considered as an "economical substitute" for other materials. The company's strategy is to provide plastic with conscious, intrinsic value as a material that is strongly expressive as well as being technically versatile and highly functional. Whether it is opaque or transparent, embossed or smooth, brightly coloured or in an elegantly natural shade, used as a single material or in a structural composite, plastic is a remarkable medium for transforming appearance and varying the decorative vernacular.



Il marchio è il primo biglietto da visita con cui un'azienda si presenta al mondo esterno.

Per questo deve contenere in sé la filosofia e la dinamicità che muovono i processi di pensiero e di produzione.

Ecco perché Con&Con ha voluto rielaborare il proprio logo, sottolineando i due elementi che da sempre gli appartengono: qualità e design.

Attraverso una grafica moderna ed essenziale, il nuovo marchio Con&Con rappresenta l'immagine stilizzata di un uomo all'interno dello spazio.

Spazio inteso come unione tra le esperienze del passato, le scoperte del presente e le sfide del futuro.

Ma spazio inteso anche come ambito di vita del genere umano, sempre alla ricerca di soluzioni innovative in grado di trasformare il vivere quotidiano in una nuova dimensione di stile e praticità.

A trade mark is the "business card" used by a company to present itself to the outside world. For this reason, it must incorporate the philosophy and the drive that animate the company's ideas and products. That is the reason why Con&Con has restyled its logo.

Its aim is to underscore quality and design, which are the two elements that have always characterised the company. Using a graphic layout that is simple and modern, the new Con&Con logo depicts the stylised image of a man inside a space.

The space is intended to represent a combination of past experiences, present discoveries and future challenges.

Yet the space also symbolises the spirit with which the human race seeks innovative solutions that advance daily living into a new dimension of style and practicality.



“ INDICE » INDEX ”



RELAX » COMFORT 6
RELAX » COMFORT

WAVY CC00354 7



APPENDERE » SOSTENERE 10
HANGING » SUPPORTING

VH CC00361/00 11
VH PARETE CC00361/10 12
VH PIANTANA CC00361/20 13
VH SOFFITTO CC00361/30 14



PORTARE 16
BEARING

BRIDGE CC00359 17



ARCHIVIARE » CONTENERE 20
STORING » CONTAINING

MAIL BOX CC00358 21



FERMARE 23
STOPPING

EX LIBRIS CC00362 24



” RELAX » COMFORT “

sgabello a dondolo impilabile

” RELAX » COMFORT “

rocking stack stool



” WAVY » ART. CC00354 “
design: Gianluigi Landoni



” WAVY » ART. CC00354 “

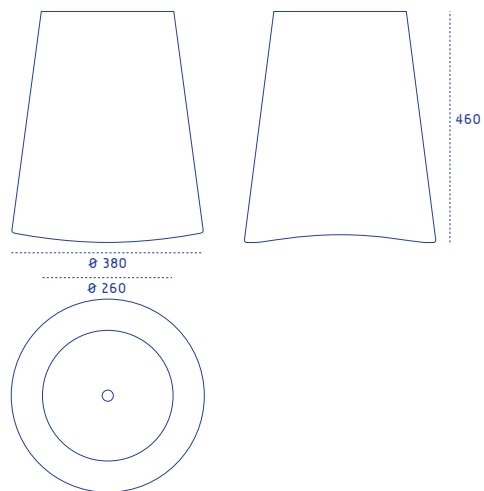

» SGABELLO A DONDOLO IMPILABILE. ROCKING STACK STOOL «

Materiale » Material : PE

Colori » Colours :



BN



AR



BL





” APPENDERE » SOSTENERE “

ganci appenditutto . portabiti . grucce
portacravatte . portascope . appendistrofinacci
gancio appenditazzine . gancio scorrevole appendiquadro
servomuto

” HANGING » SUPPORTING “

all-purpose hooks . coat hooks . coat-hangers
tie-rack . broom-holder . cloth-holder
cup-holder . sliding picture-holder hook
valet

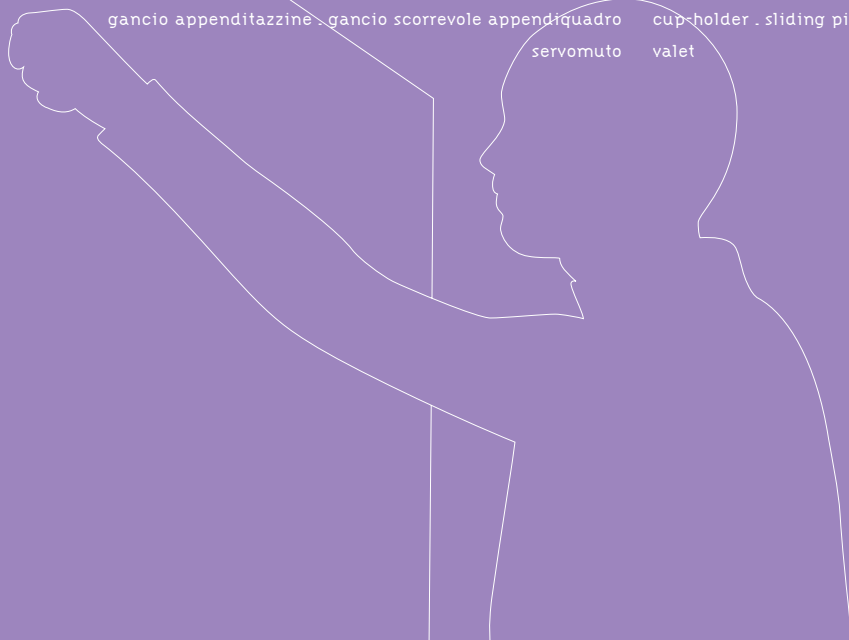

" VH » ART. CC00361/00 "
design: Simone Micheli



” VH » ART. CC00361/10 “
design: **Simone Micheli**



” VH » ART. CC00361/20 “
design: Simone Micheli



" VH » ART. CC00361/30 "
design: **Simone Micheli**



” VH » ART. CC00361 “

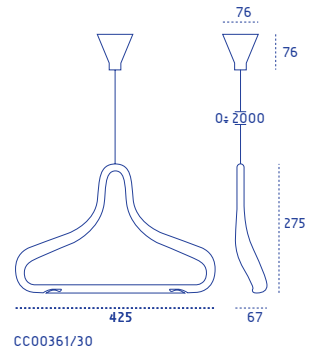
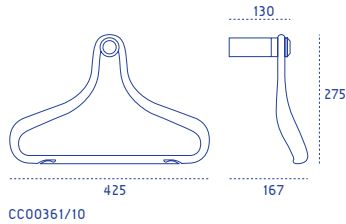
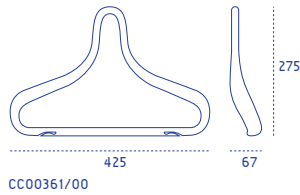
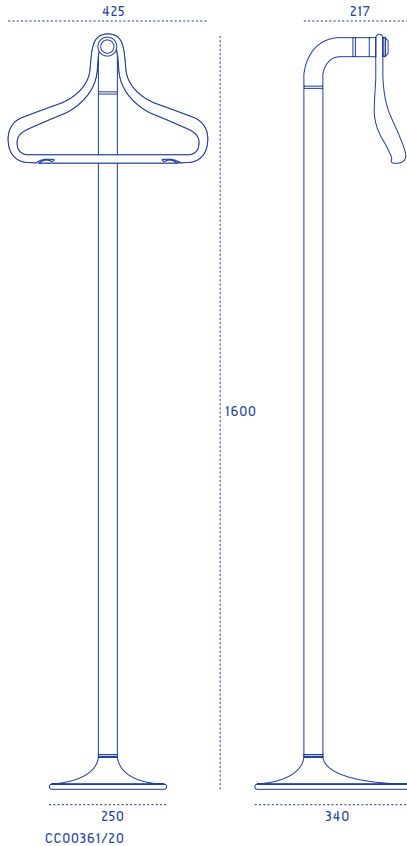

» GRUCCIA/SERVOMUTO DA PARETE/SERVOMUTO DA SOSPENSIONE/SERVOMUTO DA TERRA
 . COAT-HANGER/WALL VALET/HANGING VALET/VALET STAND «

Materiale » Material : **PA ACCIAIO ALLUMINIO**

Colori » Colours :



BN



NE



AR



” PORTARE “

portaombrelli . portachiavi . portarotolo . mensola . portafrutta
supporto mobile multiuso . portariviste . tavolino
tappettino . piano alternativo impilabile

” BEARING “

umbrella stand . key holder . kitchen towel holder . shelf . fruit rack
adjustable support/trolley . magazine rack . portable table
bits tray . alternative stackable support



” BRIDGE » ART. CC00359 “
design: Adrian Peach



” BRIDGE » ART. CC00359 “

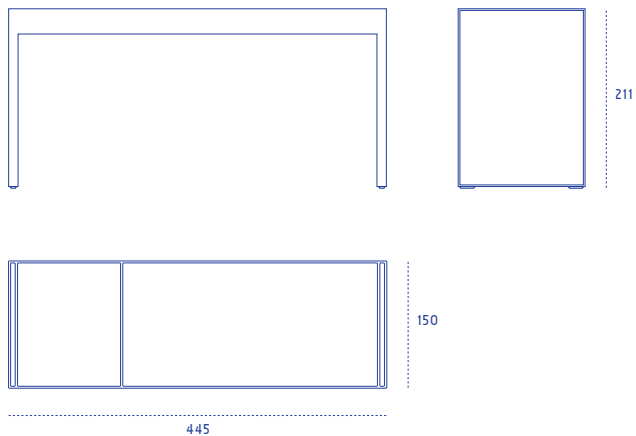

» PIANO ALTERNATIVO IMPILABILE. ALTERNATIVE STACKABLE SUPPORT «

Materiale » Material : 

Colori » Colours :



TA



TR



TG

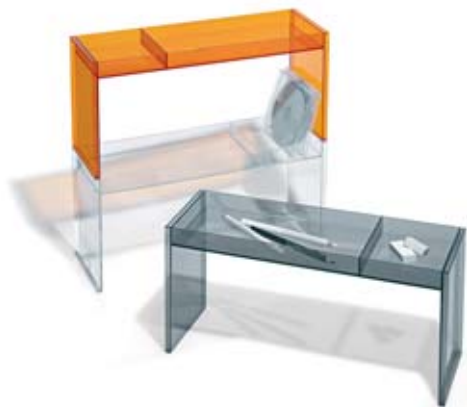



” ARCHIVIARE » CONTENERE “

scatole multiuso componibili . sistema di archiviazione a mollette
stazione di ricarica . porta cd da muro . vaso
contenitore e porta appunti da muro

” STORING » CONTAINING “

all-purpose modular boxes . clip and rail set
recharging station . cd rack . vase
wall container and note holder

” MAIL BOX » ART. CC00358 “
design: Colombo & Vantusso



” MAIL BOX » ART. CC00358 “

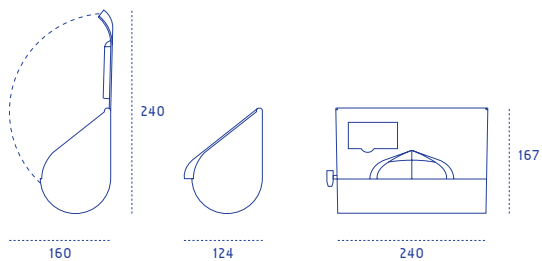

» CONTENITORE E PORTA APPUNTI DA MURO. WALL CONTAINER AND NOTE HOLDER «

Materiale » Material : PC ABS

Colori » Colours :



TA



TB



TR



TG



” FERMARE “ ” STOPPING “

fermalibri . fermalibri/riviste allungabile

bookend . exstensible bookend

fermaporta . fermacavi

door-stopper . cable holder

” EX LIBRIS (EXtended LIBrary Rigid Support) » ART. CC00362 “
design: Alberto Meda - Marco Pestalozza



” EX LIBRIS » ART. CC00362 “

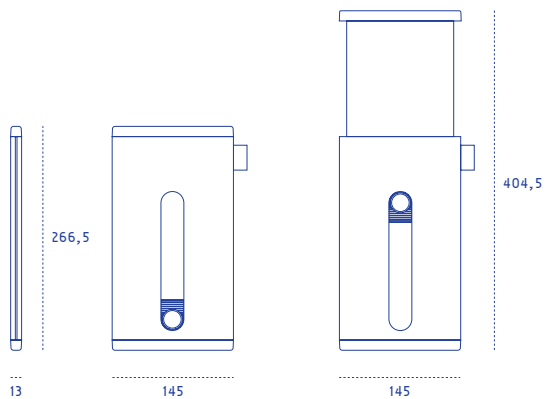

» FERMA LIBRI/RIVISTE ALLUNGABILE. EXTENSIBLE BOOKEND «

Materiale » Material :  NEOPRENE

Colori » Colours :



GLOSSARIO » GLOSSARY

- (ABS)** » **ACRILONITRILE, BUTADIENE e STIRENE** - terpolimero costituito dai tre monomeri. Materia plastica di elevata resistenza agli urti e brillantezza, qualità che la rendono adatta per oggetti d'arredo.
» **ACRYLONITRILE, BUTADIENE and STYRENE** - terpolymer made of three monomers. Thanks to its high impact strength and glossy appearance, this plastic material is especially suitable for furnishing complements.
- » **NEOPRENE** - il cui nome scientifico è "polichloroprene", appartiene alla famiglia degli elastomeri di sintesi e si presenta come una gomma porosa, la cui massa è costituita da cellule gassose uniformemente distribuite. Le principali caratteristiche sono la elasticità, la resistenza all'invecchiamento atmosferico e al calore, ed inoltre risulta essere inerte verso molti agenti chimici, olii e solventi.
» **NEOPRENE** - Neoprene, scientifically known as "polychloroprene", is part of the family of synthetic elastomers, and comes in the form of porous rubber, the mass of which is made up of uniformly distributed gas cells. Its main features include elasticity, weather and heat resistance, and inertness to many chemicals, oils, and solvents.
- (PA)** » **POLIAMMIDE 6** - è un materiale termoplastico che fa parte di una più ampia famiglia di polimeri rigidi o flessibili chiamati appunto poliammidi.
» **POLYAMIDE 6** - a thermoplastic material that belongs to a larger family of rigid or flexible polymers called polyamides.
- (PC)** » **POLICARBONATO** - resina termoplastica caratterizzata da buone proprietà di resistenza agli urti, elevata rigidità e trasparenza. Solitamente usata nelle lastre come sostituto del vetro.
» **POLYCARBONATE** - thermoplastic resin characterized by good impact strength, high rigidity and transparency. It is generally used in sheets as a substitute for glass.
- (PE)** » **POLIETILENE** - resina termoplastica ottenuta dalla polimerizzazione del propilene, molto simile al polietilene nella struttura molecolare, ma più rigido e resistente al calore, agli agenti chimici e all'abrasione.
» **POLYETHYLENE** - is a thermoplastic resin obtained from the polymerisation of propylene, very similar to polyethylene for what concerns the molecular structure, but more rigid and extremely resistant to heat, chemicals and abrasion.
- (PP)** » **POLIPROPILENE** - resina termoplastica ottenuta dalla polimerizzazione del propilene, molto simile al polietilene nella struttura molecolare, ma più rigido e resistente al calore, agli agenti chimici e all'abrasione.
» **POLYPROPYLENE** - thermoplastic resin obtained from the polymerisation of propylene, very similar to polyethylene for what concerns the molecular structure, but more rigid and extremely resistant to heat, chemicals and abrasion.
- (PS)** » **POLISTIRENE o POLISTIROLO** - resina termoplastica ottenuta dalla polimerizzazione dello stirene, con l'aggiunta di butadiene genera un copolimero più resistente. E' usato per la produzione di oggetti vari.
» **POLYSTYRENE** - thermoplastic resin obtained from the polymerisation of styrene, with the addition of butadiene it generates a stronger copolymer. Suitable for the production of various components.
- (PUR)** » **POLIURETANO** - materiale derivato da polioli di tipo poliестere e poliетere. Si presenta in forma sia flessibile che rigida. Ha ottime caratteristiche di resistenza agli urti.
» **POLYURETHANE** - material made from polyhydric alcohols of the polyester and polyether type. Can be flexible or rigid. Due to its properties has excellent impact resistance.
- (PVC)** » **POLIVINILCLORURO** - polimero termoplastico del cloruro di vinile, insolubile nella maggior parte dei solventi organici. Può essere flessibile o rigido, è usato per la realizzazione di articoli tecnici e la produzione di tubi.
» **POLY-VINYL-CLORIDE** - vinyl chloride thermoplastic polymer, non soluble in the majority of organic solvents. It can be flexible or rigid, it is used to manufacture technical components and pipes.

» I colori riportati sono puramente indicativi e possono subire variazioni. Con & Con si riserva il diritto di apportare, in qualsiasi momento, modifiche di natura tecnica o commerciale ai modelli descritti in questo catalogo.

» The colours shown are merely an indication and may undergo variations. Con & Con reserves the right, at any time, to make changes in the models in this catalogue for technical or commercial purposes.

Gruppo Confalonieri

CONFALONIERI

con&con

LORENZO INVERNIZZI

Gruppo Confalonieri spa
via Prealpi 11
I-20034 Giussano (MI)
tel. (+39) 0362.3535.1
fax (+39) 0362.851656
www.gruppoconfalonieri.it
info@gruppoconfalonieri.it